

VARIABLE SPEED WOOD LATHE

**MC900
MC1100**

Instruction Manual

Table of contents

SECTION	PAGE
I. Technical data.....	2
II. General safety rules.....	3
III. Specific safety rules for the wood lathe.....	5
IV. Electrical information.....	6
V. Know your wood lathe.....	8
VI. Assembly.....	9
VII. Adjustments	12
VIII. Operation.....	13
IX. Maintenance.....	14

I . Technical data

VARIABLE SPEED WOOD LATHE

MODEL NUMBER	MC900	MC1100
Voltage	220 – 240V	110 – 120V
Speeds	50Hz 500 – 2000 60Hz 600 - 2400	
Distance between centers	880mm	1100mm
Swing over bed	305mm	370mm
N.W./G.W.	80/85KG	92/97KG

I. General safety rules

Safety is a combination of common sense, staying alert and knowing how your wood lathe works.

WARNING: TO AVOID MISTAKES THAT COULD CAUSE SERIOUS INJURY, DO NOT PLUG THE WOOD LATHE IN UNTIL THE FOLLOWING STEPS HAVE BEEN READ AND UNDERSTOOD.

1. READ and become familiar with this entire instruction manual. Learn the tool's applications, limitations, and possible hazards.
2. AVOID DANGEROUS CONDITIONS. DO NOT use power tools in wet or damp areas or expose them to rain. Keep work area well lit.
3. DO NOT use power tools in the presence of flammable liquids or gases.
4. ALWAYS keep your work area clean, uncluttered and well lit. DO NOT work on floor surfaces that are slippery with sawdust or wax.
5. KEEP BYSTANDERS AT A SAFE DISTANCE FROM the work area, especially when tool is operating. NEVER allow children near the tool.
6. DO NOT FORCE THE TOOL to do a job for which it was not designed.
7. DRESS FOR SAFETY. DO NOT wear loose clothing, gloves, neckties, or jewelry (rings, watches) when operating tool. They can get caught and draw you into moving parts. ALWAYS wear non-slip footwear, and tie back long hair.
8. WEAR A FACE MASK OR DUST MASK. Wood lathe operation produces dust.
9. ALWAYS remove the power cord plug from the electrical outlet when making adjustments, changing parts, cleaning or working on tool.
10. AVOID ACCIDENTAL START-UPS. Make sure that the power switch is in the "OFF" position before plugging in the power cord.
11. REMOVE ADJUSTING TOOLS. ALWAYS MAKE SURE all tools are removed from the wood lathe before turning it on.
12. NEVER LEAVE A RUNNING TOOL UNATTENDED. Turn the power switch to "OFF." DO NOT leave tool until it has come to a complete stop.
13. NEVER STAND ON A TOOL. Serious injury could result if the tool tips or is accidentally hit. DO NOT store anything above or near the tool.

SAVE THESE SAFETY RULES

II . General safety rules—Continued

14. **DON'T OVERREACH.** Keep proper footing and balance at all times. Wear oil-resistant, rubber-soled footwear. Keep floor clear of oil, scrap and other debris.
15. **MAINTAIN TOOLS PROPERLY.** ALWAYS keep tools clean and in good working order. Follow instructions for lubricating and changing accessories.
16. **CHECK DAMAGED PARTS.** Check for alignment of moving parts, binding of moving parts, breakage of parts, improper mounting or any other conditions that may affect the tool's operation. Any part that is damaged should be properly repaired or replaced before use.
17. **MAKE WORKSHOP CHILDPROOF.** Use padlocks, master switches, and ALWAYS remove starter keys.
18. **DO NOT** operate tool if you are under the influence of any drugs, alcohol or medication that could affect your ability to use the tool properly.
19. **WARNING:** Dust generated from certain materials can be hazardous to your health. Always operate lathe in a well-ventilated area and provide for proper dust removal. Use dust collection systems whenever possible.



ALWAYS WEAR EYE PROTECTION.

A wood lathe can throw foreign objects into the eyes which could cause permanent eye damage.

ALWAYS wear safety goggles (not glasses). Ordinary eyeglasses have only impact-resistant lenses... they ARE NOT safety goggles.

WIRING DIAGRAM

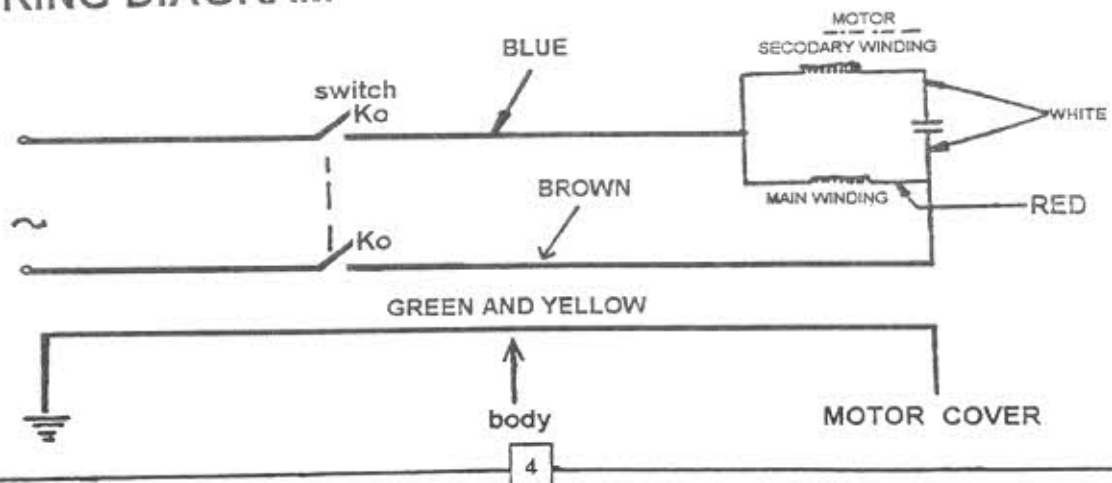

II . Specific safety rules for the wood lathe

WARNING: DO NOT OPERATE YOUR WOOD LATHE UNTIL IT IS COMPLETELY ASSEMBLED AND INSTALLED ACCORDING TO THE INSTRUCTIONS.

1. For your own safety, read the entire instruction manual before operating the lathe.
2. ALWAYS wear eye protection.
3. Do not wear gloves, necktie, or loose clothing.
4. Tighten all locks before operating.
5. Do not mount a split workpiece.
6. Use the lowest speed when starting a new workpiece.
7. Read the warning label attached to the wood lathe.
8. When turning a workpiece, always rough the wood to round form at slow speed. If the lathe is run so fast that it vibrates, there is a risk that the workpiece will be thrown or the tool jerked from your hands.
9. Always rotate the workpiece by hand before turning on the motor. If the workpiece strikes the tool rest, it could split and be thrown out of the lathe.
10. Do not allow the turning tools to bite into the wood. The wood could split or be thrown from the lathe.
11. Always position the tool rest above the centerline of the lathe when shaping a piece of stock.
12. Do not operate the lathe if it is rotating in the wrong direction. The workpiece must always be rotating toward you.
13. Before attaching a workpiece to the faceplate, always rough it out to make it as round as possible. This minimizes the vibrations while the piece is being turned. Always fasten the workpiece securely to the faceplate. Failure to do so could result in the workpiece being thrown from the lathe.
14. Position your hands so that they will not slip onto the workpiece.
15. Remove all loose knots in the stock before mounting it between the centers or on the faceplate.

SAVE THESE SAFETY RULES

III. Specific safety rules for the wood lathe—Continued

16. Leave the work area only after the lathe's motor has come to a full stop.
17. Hang your turning tools on the wall beyond the tailstock end of the lathe. Do not lay them on the bench so that you must reach over the revolving workpiece to select them.
18. Keep a firm hold and remain in control of the cutting tool at all times. Take special precautions when shaping a section of stock in which knots or voids are found.
19. Always make safety come first.
20. Complete the hand-sanding of all workpieces BEFORE you remove them from the lathe.

SAVE THESE SAFETY RULES

IV. Electrical information

GROUNDING INSTRUCTIONS

IN THE EVENT OF A MALFUNCTION OR BREAKDOWN, grounding provides the path of least resistance for electric current to reduce the risk of electric shock. This tool is equipped with an electric cord that has an equipment grounding conductor and a grounding plug. The plug **MUST** be plugged into a matching outlet that is properly installed and grounded in accordance with ALL local codes and ordinances.

DO NOT MODIFY THE PLUG PROVIDED. If it will not fit in the outlet, have the proper outlet installed by a qualified electrician.

IMPROPER CONNECTION of the equipment grounding conductor can result in risk of electric shock. The conductor with the green insulation (with or without yellow stripes) is the equipment grounding conductor. If repair or replacement of the electric cord or plug is necessary, **DO NOT** connect the equipment grounding conductor to a live terminal.

CHECK with a qualified electrician or service person if you do not completely understand the grounding instructions, or if you are not sure the tool is properly grounded.

USE ONLY THREE WIRE EXTENSION CORDS that have 3-prong grounding type plugs and 3-hole receptacles that accept the tool's plug as shown in Fig. A. Repair or replace damaged or worn cord immediately.

CAUTION: IN ALL CASES, MAKE CERTAIN THE RECEPTACLE IN QUESTION IS PROPERLY GROUNDED. IF YOU ARE NOT SURE, HAVE A CERTIFIED ELECTRICIAN CHECK THE RECEPTACLE.

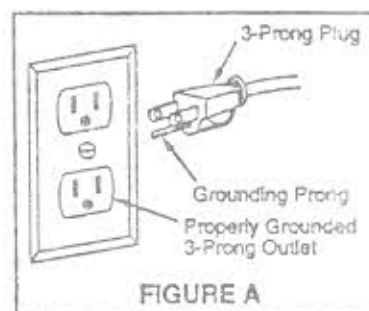

SAVE THESE SAFETY RULES

IV. Electrical information

GUIDELINES FOR USING EXTENSION CORDS

WARNING: THIS WOOD LATHE IS FOR INDOOR USE ONLY. DO NOT EXPOSE TO RAIN OR USE IN DAMP LOCATIONS.

Make sure your extension cord is in good condition. When using an extension cord, be sure to use one heavy enough to carry the current your product will draw. An undersized cord will cause a drop in line voltage resulting in loss of power and overheating. The table below shows the correct size to use according to cord length and nameplate ampere rating. If in doubt, use the next heavier gauge. The smaller the gauge number, the heavier the cord.

MINIMUM GAUGE FOR EXTENSION CORDS (AWG)					
(when using 120 volts only)					
Ampere Rating		Total length of cord in feet			
more than	not more than	25'	50'	100'	150'
0	6	18	16	16	14
6	10	18	16	14	12
10	12	16	16	14	12
12	16	14	12	Not Recommended	

Be sure your extension cord is properly wired and in good condition. Always replace a damaged extension cord or have it repaired by a qualified person before using it. Protect your extension cords from sharp objects, excessive heat and damp or wet areas.

Use a separate electrical circuit for your tools. This circuit must not be less than #12 wire and should be protected with a 15 Amp time lag fuse. Before connecting the motor to the power line, make sure the switch is in the "OFF" position and the electric current is rated the same as the current stamped on the motor nameplate. Running at a lower voltage will damage the motor.

WARNING: THIS TOOL MUST BE GROUNDED WHILE IN USE TO PROTECT THE OPERATOR FROM ELECTRICAL SHOCK.

SAVE THESE SAFETY RULES

V. Know your wood lathe

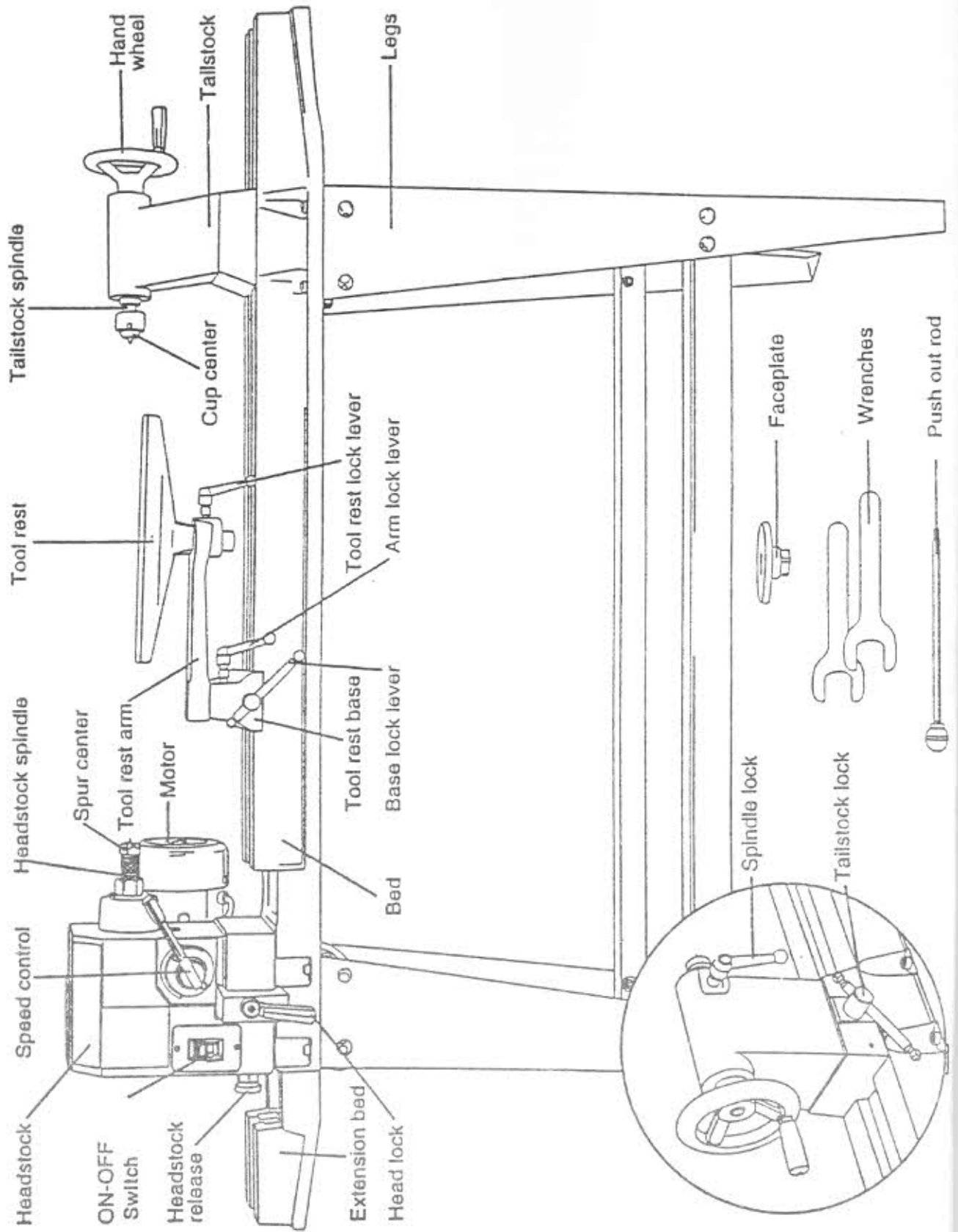

VI. Assembly

Unpacking (figure 1)

1. Carefully remove the leg set and wood lathe from the carton.

CAUTION: THE WOOD LATHE IS VERY HEAVY AND MUST BE LIFTED WITH THE HELP OF 2 PEOPLE OR MORE. THE ASSEMBLY PROCESS REQUIRES 2 PEOPLE OR MORE TO SAFELY ASSEMBLE THE LATHE TO THE LEG SET.

2. Separate the parts for the leg set from the parts of the lathe.

3. Lay out all parts and check them against the parts listed below. Examine all parts carefully.

WARNING: IF ANY PART IS MISSING OR DAMAGED, DO NOT PLUG THE WOOD LATHE IN UNTIL YOU HAVE REPLACED THE MISSING OR DAMAGED PART

For your safety, complete the assembly of the lathe before plugging it into the power supply.

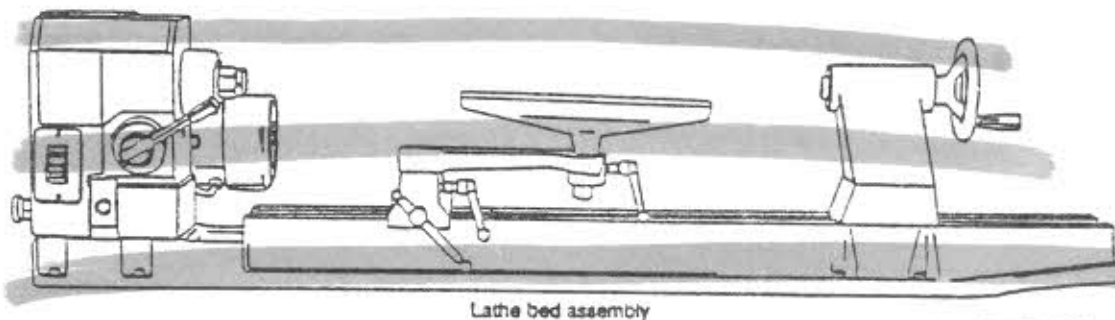
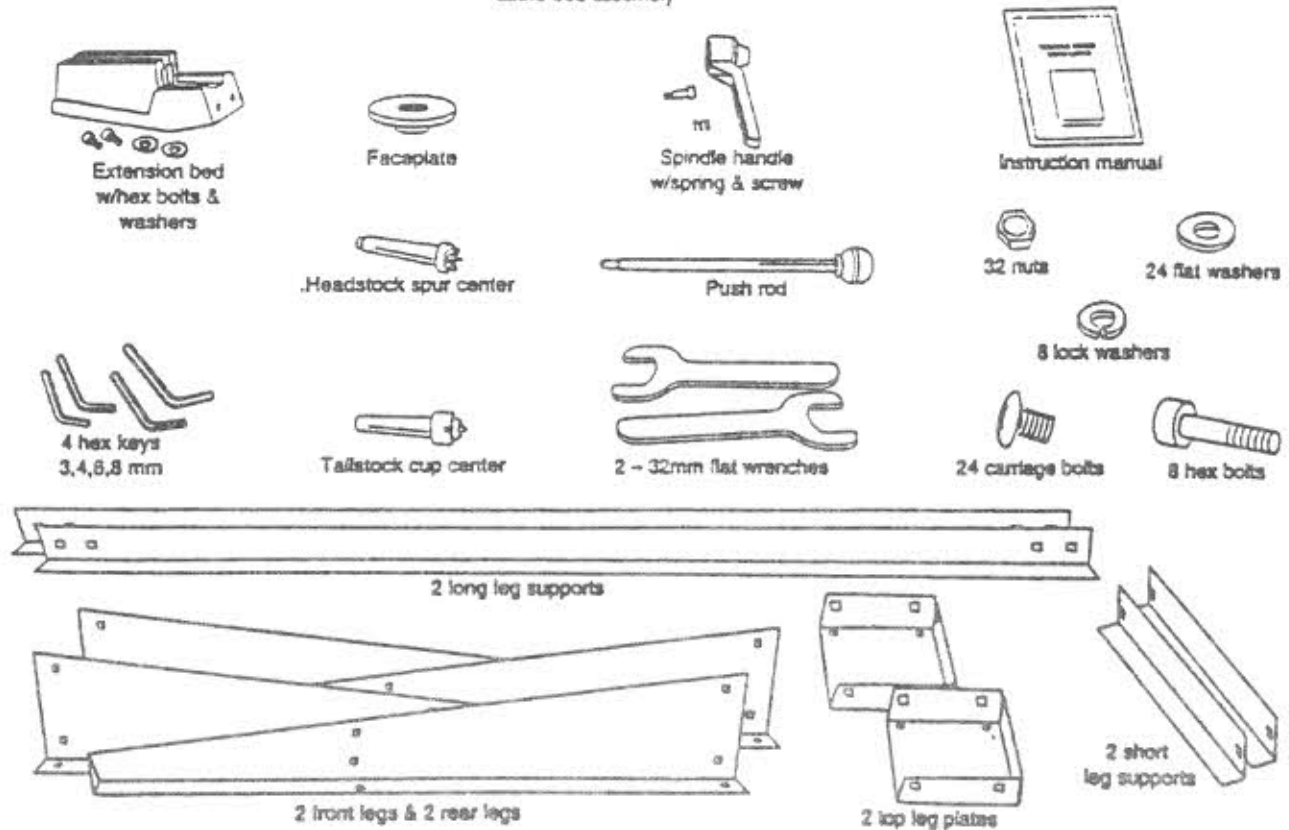

Fig. 1

Lathe bed assembly



VI. Assembly

Erecting the leg set (Figure 2)

1. Attach one front and one back leg [1] to the outside edge of the top plate [2] using carriage bolts [3], washers [4], and nuts [5].
2. Position the top plate so that it fits inside the legs.
3. Repeat step 1 for the opposite side.
4. Attach long supports [6] to legs using carriage bolts, washers and nuts.
5. Attach short supports [7] to legs using carriage bolts, washers, and nuts.
6. Place the stand on a level surface and tighten all nuts securely using a 14 mm wrench or adjustable wrench.

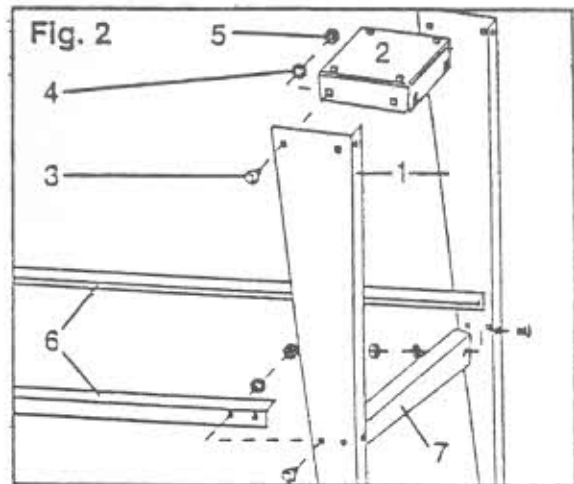

Setting the lathe on the leg set (Figure 3)

1. Place the lathe bed assembly [1] on the leg set.
2. Position the headstock [2] assembly over the top plate and align the holes in the bed [3] with the holes in the top plate [4]. Set the headstock down carefully.
3. Align the tailstock assembly end of the lathe over the top plate mounting holes and set it down carefully.
4. Insert the hex bolts [5] into the mounting holes in each bed and into the top plate.
5. Thread washer [6] and nut [7] onto bolt [5], and tighten securely.

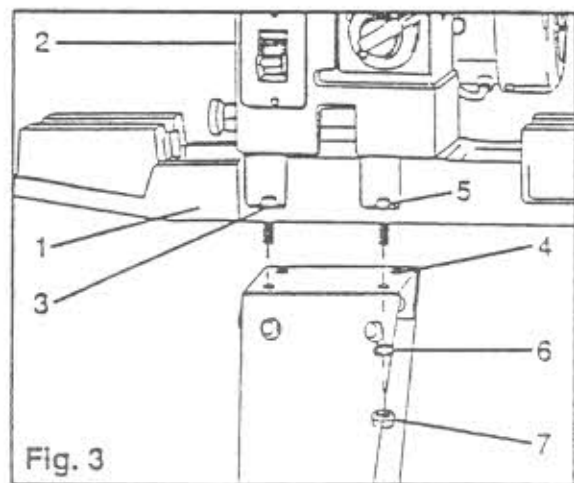

IMPORTANT: THE LEG SET MUST BE FASTENED TO THE SUPPORTING SURFACE.

Head lock handle (Figure 4)

1. Locate and assemble the head locking handle [1], spring [2] and bolt [3] as shown.
2. Thread assembled handle into the head locking clamp [4] and tighten.

NOTE: Spring loaded handles

The spring loaded handles on the lathe are designed to minimize interference with other lathe parts or the workpiece. To operate, push the handle lever in and turn clockwise to tighten. Releasing the handle lever will disengage the threaded shaft, allowing you to reposition the lever handle so it is out of the way.

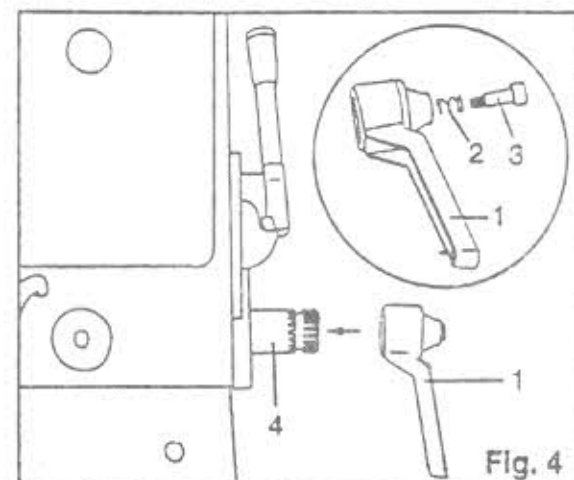

VI. Assembly

Spurs

1. Remove the faceplate [1] from the headstock spindle using the two wrenches provided [2] to separate the faceplate from the spindle nut. (Figure 5)
2. Insert the headstock spur [3] in the spindle hole.
3. Insert the tailstock center [4] in the tailstock hole. (Figure 6)
4. To remove either the headstock spur or the tailstock center, insert the push-out rod [5] into the hole [6] at the opposite end of the headstock or tailstock. Remove and store the rod in a safe location after use.

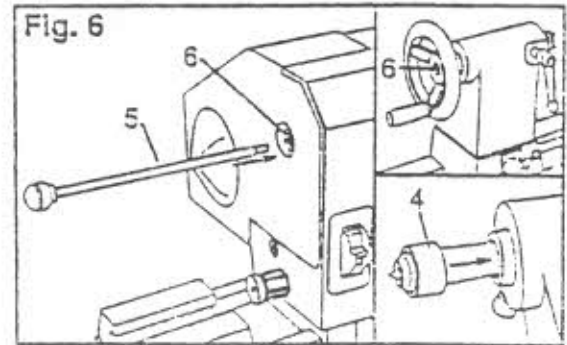
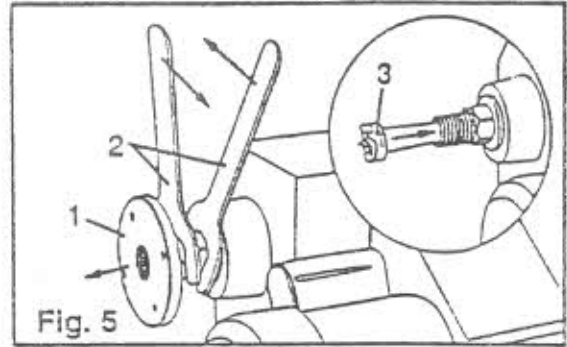

Faceplate (Figure 7)

1. Remove the headstock spur from the spindle.
2. Thread the 4 inch diameter faceplate to the spindle.
3. Mount the workpiece to the faceplate with the flat head brass wood screws. Make sure the length of the screws does not interfere with the cutting tools.

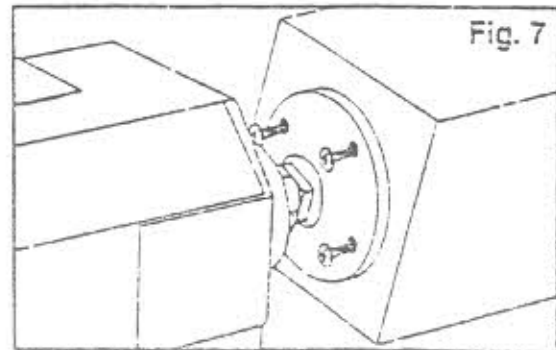

Extension bed (Figure 8)

1. The extension bed is attached to the left of the headstock for outboard faceplate turning when the use of the tool rest is required.
2. If outboard faceplate turning does not require the use of the tool rest, do not attach the extension bed until needed.
3. To attach the extension bed [1] to the bed, align the bolt holes [2] with the threaded bed holes [3]. Put the lock washer [4] on the hex bolt [5]. First finger tighten the hex bolt, then secure the hex bolt with the hex key provided.

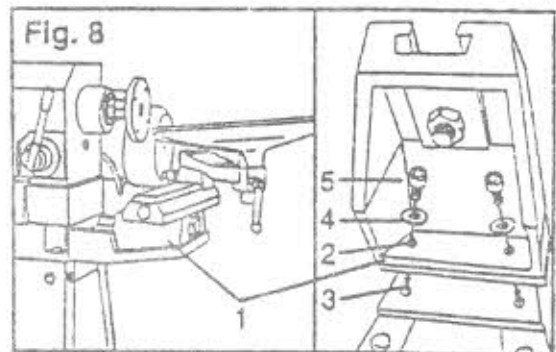

WARNING: DO NOT OPERATE YOUR WOOD LATHE UNTIL IT IS COMPLETELY ASSEMBLED AND ADJUSTED ACCORDING TO THE INSTRUCTIONS.

VI. Adjustments

Headstock (Figure 9)

1. The headstock has 5 preset positions.
 - 0° setting for all spindle turning applications.
 - $60^\circ / 90^\circ / 120^\circ$ for use when making face plate turnings.
 - 180° for use for face plate turnings when using the extension bed and tool rest.
2. To set the headstock at the desired position, you must first turn the head lock handle [1] until you have completed at least one rotation. (Figure 10)
3. Pull out the headstock release [2]. Rotate the entire headstock clockwise to the desired setting. The headstock will be fixed in position when it clicks into one of the five preset settings. Tighten the lock handle [1].

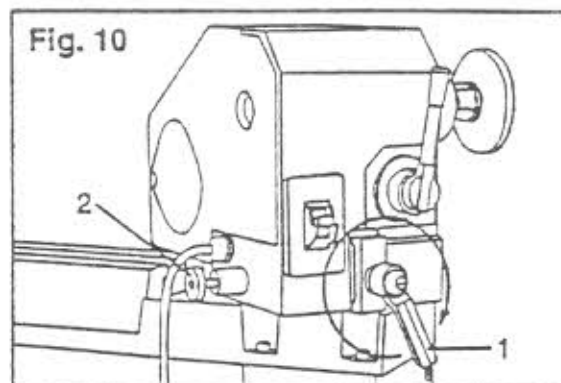
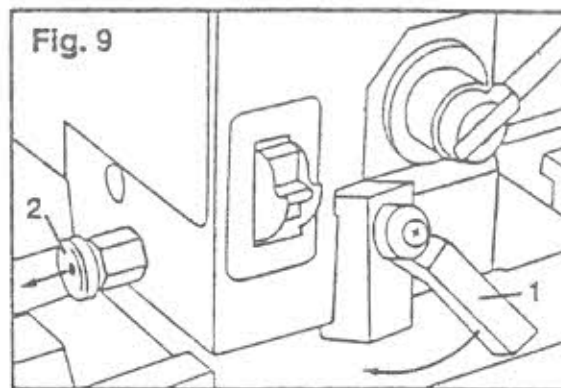
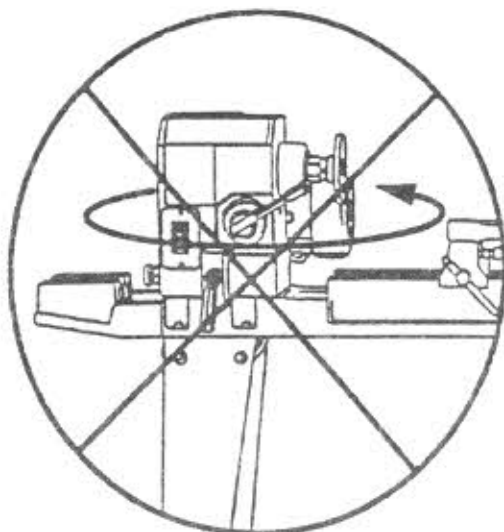
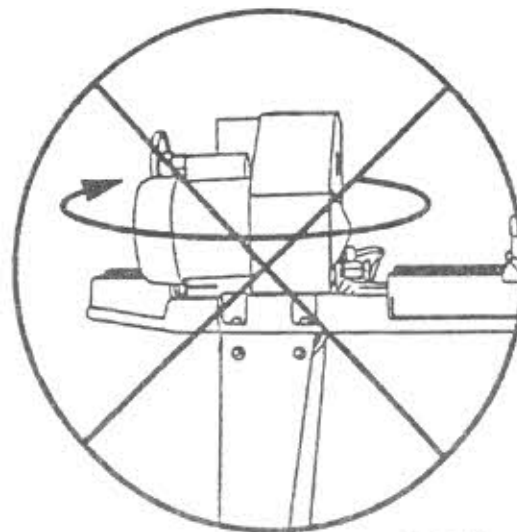

Fig. 11

WARNING: DO NOT TURN THE HEADSTOCK ASSEMBLY MORE THAN 180° CLOCKWISE FROM THE SPINDLE SETTING POSITION OR DAMAGE TO WIRING MAY OCCUR.



DO NOT TURN THE HEADSTOCK ASSEMBLY COUNTERCLOCKWISE BEYOND THIS POSITION



DO NOT TURN THE HEADSTOCK ASSEMBLY CLOCKWISE BEYOND THIS POSITION

VIII. Operation

Switch (Figure 12)

1. To turn the lathe "ON", insert the yellow switch key into the switch housing.
2. Move the switch to the "ON" position.
3. To turn the lathe "OFF", move the switch to the "OFF" position.
4. To lock the switch in the "OFF" position, remove the yellow switch key from the switch housing. Store it in a safe place.
5. Never leave the lathe unattended until it has come to a complete stop.

Fig. 12



Speed control (Figure 13)

1. The lathe motor must be running before you can use the speed control lever.
2. The speed control lever can be turned to one of ten fixed speeds. To set the speed, pull back on the lever handle [1] and rotate the handle to the next fixed speed. Use the index plate [2] to choose lathe speed.
3. Turn the lever clockwise to increase the speed and counterclockwise to decrease the speed.
4. You must move the speed control lever to the lowest speed setting before turning the switch off (Figure 14), otherwise the motor may not start.

Fig. 13

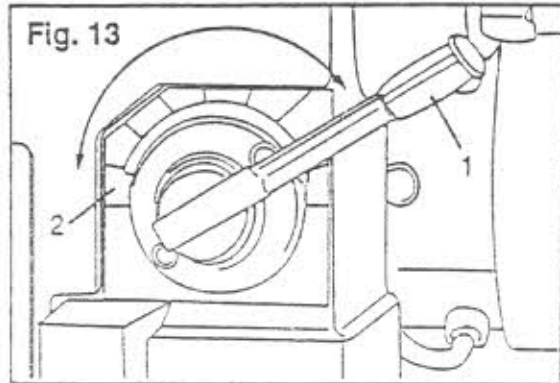
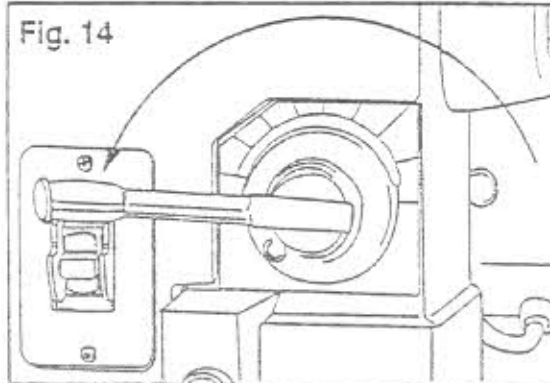

Fig. 14



Tailstock (Figure 15)

1. Move the tailstock [1] by loosening the lock lever [2] and pushing the tailstock to the desired position on the bed. Lock by tightening the lock lever [2].
2. The spindle can extend up to 2-1/2 inches from the tailstock housing. You can move the tailstock spindle [3] by loosening the spindle lock lever [4] and then turning the hand wheel [5]. Lock levers [4] and [2] before operating lathe.
3. The tailstock spindle is hollow and can be accessed from the handwheel end. Use the push-out rod to remove the center cup or to drill holes through the center of a workpiece.

Fig. 15

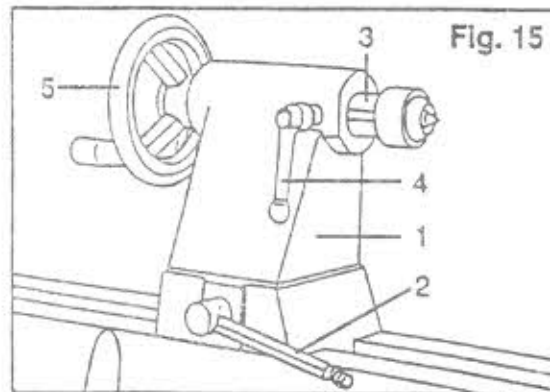

VIII. Operation

Tool rest (Figure 16)

1. The tool rest [1] can be used with or without the arm [2].
2. To move the tool rest base [3], loosen the lock lever [4], and move the base to the right or left and back or front. Tighten the lever [4] when the tool rest base is in the desired position.
3. When using the arm [2], make the necessary adjustments using lock levers [5] and [6] to position the tool rest.
4. Tighten all tool rest lever handles [4-5-6] and ensure there is adequate clearance between the workpiece and the tool rest assembly before turning the lathe on.
5. The tool rest can also be repositioned to the extension bed for use on outboard turnings. (Figure 17)

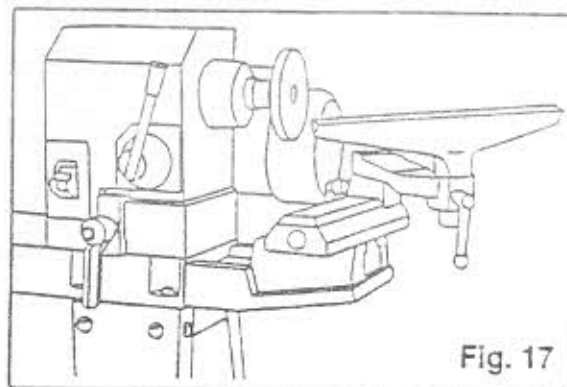
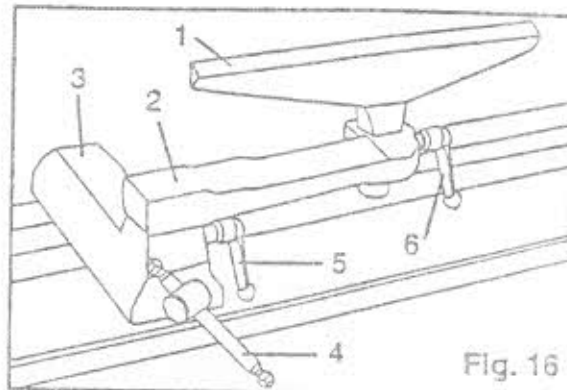

IMPORTANT: MAKE SURE THE TOOL REST IS ADJUSTED TO BE AS CLOSE TO THE WORKPIECE AS POSSIBLE. ROTATE THE WORKPIECE BY HAND TO CHECK CLEARANCE BEFORE TURNING THE LATHE "ON".

IX. Maintenance

WARNING: FOR YOUR OWN SAFETY, TURN THE SWITCH "OFF" AND REMOVE THE PLUG FROM THE ELECTRICAL OUTLET BEFORE PERFORMING MAINTENANCE OR LUBRICATION WORK ON THE LATHE.

1. Blow out dust accumulation inside the motor, housing, and bed assembly frequently.
2. A coat of automotive wax applied to the bed will help keep the surface clean and the movement of the tool rest and tailstock smooth.
3. Periodic lubrication of the spring levers and other threaded parts will make these parts easier to operate.

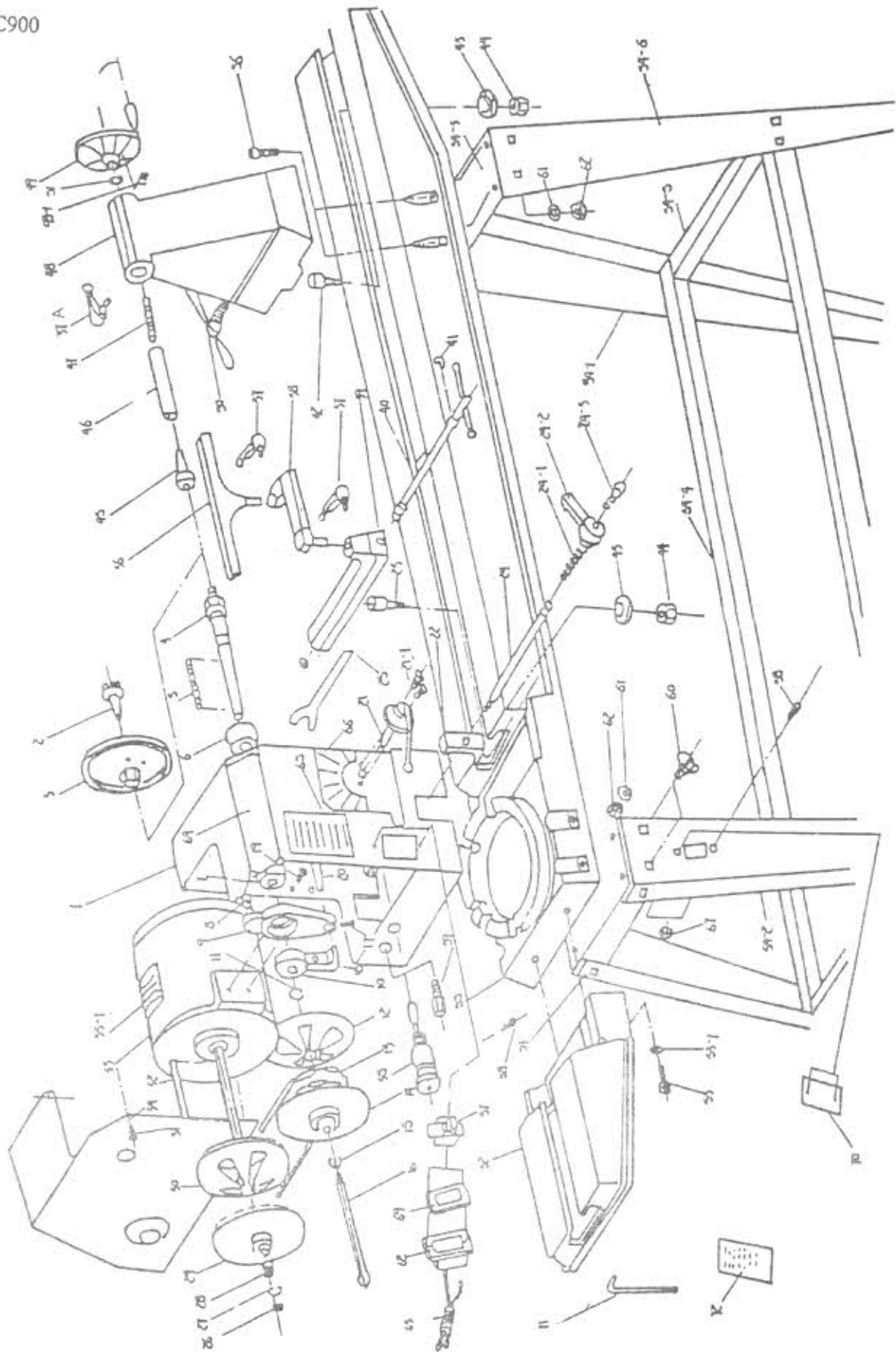

PARTS LIST

ITEM	DESCRIPTION	Q' TY	ITEM	DESCRIPTION	Q' TY
M1	HEADSTOCK	1	M39	TOOL REST BODY	1
M2	HEADSTOCK SPUR	1	M40	ECCENTRIC ROD	1
M3	FACEPLATE	1	M41	"C"RING S-19	1
M4	SPINDLE	1	M42	BOLT	2
M5	KEY 4X4X80(mm)	1	M43	CLAMP	2
M6	BEARING 8020SZ	1	M44	HEX NUT M18	2
M7	BEARING 8020SZ	1	M45	TAILSTOCK LOCK	1
M8	SPRING	1	M46	TAIL SPINDLE	1
M9	BRACKET—SHIFING LEVER	1	M47	TAIL STOCK SCREW	1
M10	BALL BEARING 6006Z	1	M48	TAILSTOCK	1
M11	"C"RING S-25	1	M48-1	SOCKEY HEAD SET SCREW M6X19	1
M12	PULLEY—SPINDLE(RIGHT)	1	M49	HANDLE WHEEL	1
M13	V—BELT	1	M50	LOCK HANDLE—TAILSTOCK	1
M14	PULLEY—SPINDLE(LEFT)	1	M51	WASHER	1
M15	"C"RING S-24	1	M52	EXTENSION BED	1
M16	PUSH—OUT ROD	1	M53	SCREW M10X25	2
M17	NUT—LOCK M12	1	M53-1	SPRING WASHER	2
M18	CLAMP—LEFT	1	M54	STAND ASSEMBLY	
M19	HEX HD. SCREW M8X25	2	M54-1	STAND LEG	1
M20	BACK	1	M54-2	STAND SWITCH LEG	1
M21	GEAR ASSEMBLY	1	M54-3	STAND UPPER COVER	2
M21-1	HEX SOCKEY HD. SCREW	2	M54-4	STAND LONG—CROSS SUPPORT	2
M22	CLAMP—RIGHT	1	M54-5	STAND SHORT—CROSS SUPPORT	2
M71	HEX WRENCH	4	M54-6	STAND LEG	2
M24	KNOB	1	M55	BED	1
M25	SPINDLE WRENCH	2	M56	SCREW M8X16	8
M26	"C"RING S-16	1	M57	SWITCH	1
M27	SLEEVE	1	M58	SCREW M4X16	2
M28	SPRING	1	M59	PLASTIC JAM NUT M20X1.5	1
M29	PULLEY—MOTOR(RIGHT)	1	M60	CARRIAGE BOLT STAND	24
M30	PULLEY—MOTOR(LEFT)	1	M61	WASHER—STAND	24
M31	SCREW M5X10	4	M62	NUT STAND	32
M32	KEY 4X4X85(mm)	1	M63	POWER CORD	1
M33	MOTOR	1	M64	NAME LABLE	1
M33-1	NAME PLATE FOR MOTOR	1	M65	WARNING LABLE	1
M34	COVER—MOTOR	1	M66	SPEED LABLE	1
M35	ANGULAR SETTING ASSEMBLY	1	M67	NUT M4	2
M36	TOOL REST	1	M68	SWITCH BOX	1
M37	HANDLE FOR TOOL REST	2	M69	SWITCH FIXING PLATE	1
M38	EXTENSION TOOL REST	1	M70	COVER	1
M37A	HANDLE FOR TAILSTOCK	1			

MC1100

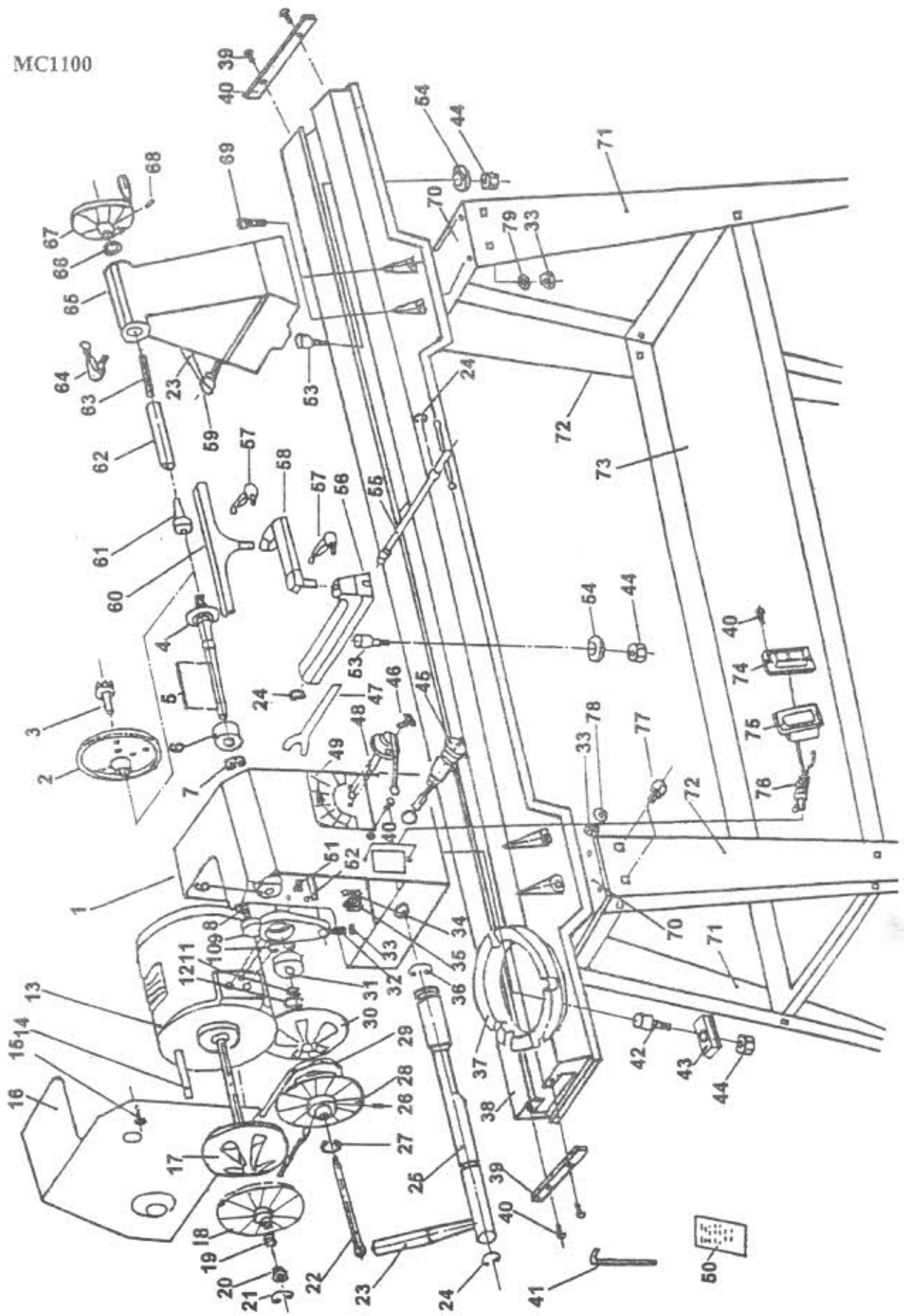

PART LIST

NO.	DESCRIPTION	Q'TY	NO.	DESCRIPTION	Q'TY
1.	HEADSTOCK	1	41.	HEX WRENCH	4
2.	FACEPLATE	1	42.	BOLT-A	1
3.	DRIVING CENTER	1	43.	CLAMP-A	1
4.	SPINDLE	1	44.	HEX NUT	3
5.	KEY	1	45.	ANGULAR SETTING ASSEMBLY	1
6.	BEARING	2	46.	SCREW	2
7.	"C" RING	2	47.	SPINDLE WRENCH	2
8.	SPRING	1	48.	GEAR ASSEMBLY	1
9.	BRACKET-SHIFING LEVER	1	49.	SPEED LABLE	1
10.	"C" RING	1	50.	INSTRUCTION MANUAL	1
11.	"C" RING	1	51.	HEX SCREW	3
12.	"C" RING	1	52.	RACK	1
13.	MOTOR	1	53.	BOLT-B	2
14.	KEY	1	54.	CLAMP-B	2
15.	SCREW	4	55.	ECCENTRIC ROD	1
16.	COVER-MOTOR	1	56.	TOOL REST BODY	1
17.	PULLEY-MOTOR (LEFT)	1	57.	HANDLE ASSEMBLY	2
18.	PULLEY-MOTOR (RIGHT)	1	58.	EXTENSION TOOL REST	1
19.	SPRING	1	59.	LOCK HANDLE TAIL STOCK	1
20.	SLEEVE	1	60.	TOOL REST	1
21.	"C" RING	2	61.	TAILSTOCK SPUR	1
22.	PUSH-OUT ROD	1	62.	TAIL SPINDLE	1
23.	HANDLE	2	63.	TAILSTOCK SCREW	1
24.	"C" RING	3	64.	HANDLE ASSEMBLY	1
25.	ECCENTRICITY ROD	1	65.	TAIL STOCK	1
26.	SCREW	1	66.	WASHER	1
27.	"C" RING	1	67.	HANDLE WHEEL	1
28.	PULLEY-SPINDLE (LEFT)	1	68.	SCREW	1
29.	V-BELT	1	69.	SCREW	8
30.	PULLEY-SPINDLE (RIGHT)	1	70.	STAND UPPER COVER	2
31.	BEARING	1	71.	STAND LEG-I	2
32.	NUT-LOCK	1	72.	STAND LEG-II	2
33.	NUT	29	73.	TOOL TABLE	1
34.	CLAMP	2	74.	SWITCH	1
35.	NUT M4	2	75.	SWITCH BOX	1
36.	"C" RING	1	76.	POWER CORD	1
37.	TURNING BASE	1	77.	CARRIAGE BOLT STAND	20
38.	BED	1	78.	WASHER-STAND	20
39.	BAFFLE	2	79.	SPRING WASHER	8
40.	SCREW	4			